

RIGOL

DP700 Rack Mount Kit

RM-3-DP700

This rack mount kit (RM-3-DP700) is designed to mount three **RIGOL** DP700 series programmable linear DC power supplies into a 19-inch cabinet that conforms to the Electronic Industries Association (EIA) standard.

Kit Part Checklist (RM-3-DP700)

No.	Name	Qty.	Description
1	Right Fastener	1	--
2	Connecting Plate A	2	--
3	Connecting Plate B	2	--
4	Left Fastener	1	--
5	M4 Screw	28	M4x8 Phillips Pan Head Screw
6	M4 Screw	8	M4x8 Phillips Countersunk Flat Head Screw
7	Rail	2	--
8	Bottom Plate	1	--
9	Side Beam Fastener	4	--
10	Retaining Bracket	4	--
11	M6 Screw	12	M6x16 Phillips Pan Head Screw
12	M6 Nut	12	M6 Square Lock Cage Nut

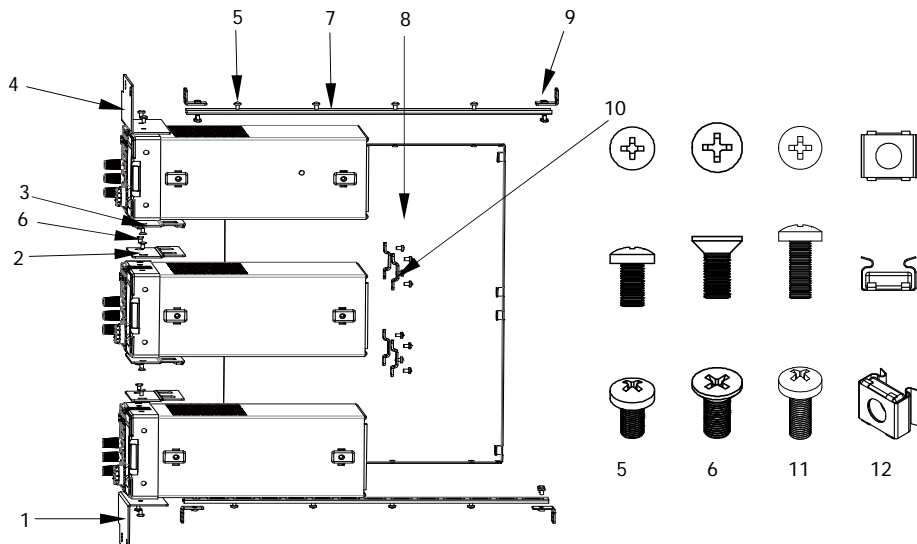

Installation Tool

The PH2 Philips screwdriver is recommended.

Space Requirements

To mount the instrument into the cabinet correctly, please ensure that the following requirements are met:

- The cabinet must be a standard 19-inch one.
- The available height of the cabinet should be at least 4U.
- The depth of the cabinet should be at least 500 mm.

The dimensions of the rack are as shown below.

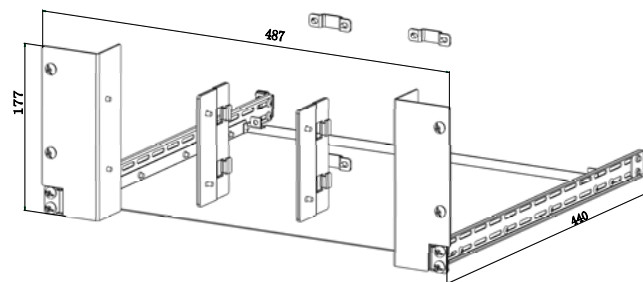

Unit: mm

Installation Procedures



CAUTION

Only authorized operators are allowed to perform the installation. Improper installation might cause damage to the instrument or an installation failure.

1. Remove the four rubber protective covers located at the four corners of the front panel and the four ones at the corners of the rear panel of the instrument respectively.
2. Attach two rails (with the U-channel facing outward) to both sides of the bottom plate, and then fasten them with eight M4 pan head screws.
3. Attach two side beam fasteners to the front ends of each rail, as shown in the figure below, and then secure them with four M4 pan head screws.

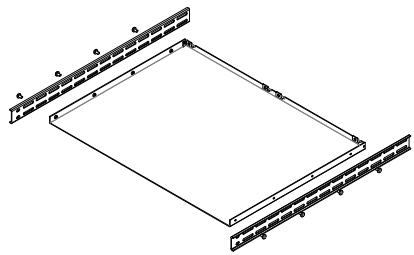

4. Secure the side beam fasteners to the cabinet by using four M6 screws and four M6 nuts.

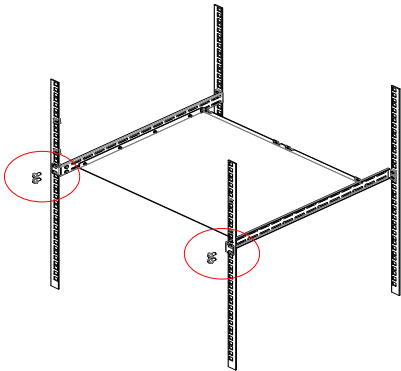

6. Attach each pair of connecting plates to two adjacent instruments respectively (first mount Connecting Plate A at the left side of Instrument A, and then mount Connecting Plate A and B in an alternating order), and secure them with eight M4 countersunk flat head screws.

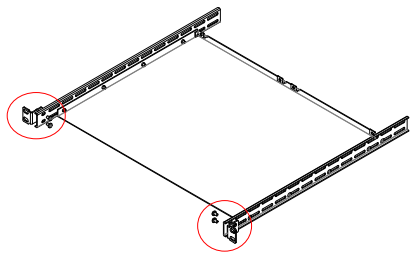

5. Attach another two side beam fasteners to the back ends of each rail respectively, as shown in the figure below, and then secure them with four M4 pan head screws. Use four M6 screws and four M6 nuts to secure the side beam fasteners to the cabinet.

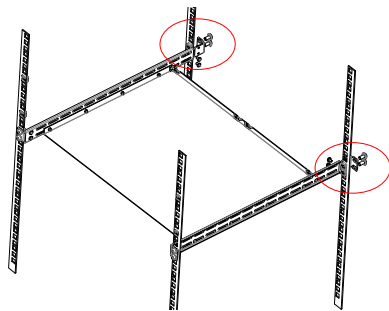

7. Connect the three instruments by joining each pair of connecting plates.

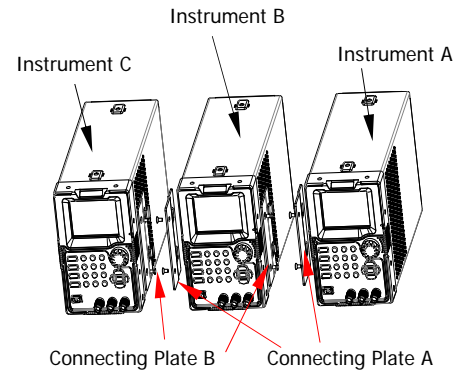

8. Place four retaining brackets onto the connecting positions of the rear panels of the three instruments, and then secure the retaining brackets with eight M4 pan head screws.

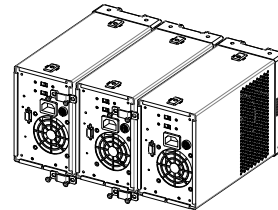

10. Attach the right fastener to the right side of Instrument A, then secure it with two M4 pan head screws.

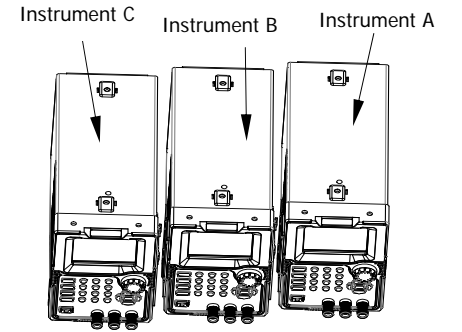
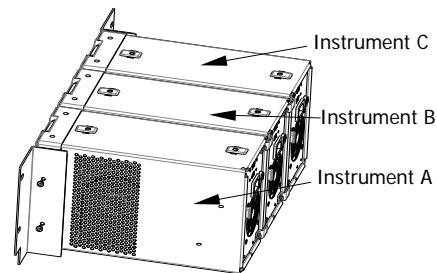

9. Attach the left fastener to the left side of Instrument C, and secure it with two M4 pan head screws.

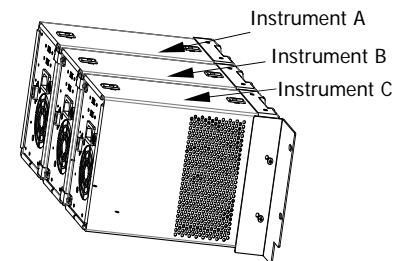

11. Place the assembled instruments and rack onto the bottom plate. Then, secure the left and right fasteners to the cabinet by using four M6 screws and four M6 nuts.

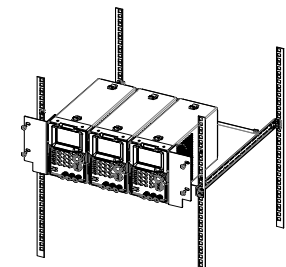

-End-